

S150 Series



S150R



S150R-FT

PRODUCT SPECIFICATION

S150R | S150RLR
S150R-FT | S150RLR-FT

Materials Lens-PC, Housing-STSS, Reflector-PC, Reflector-Heat resistant ABS, Mounting bracket-STSS316L
Ambient operating temperature -20°C to +50°C
Protection rating IP44
Revolving speed 120-140RPM

- Stainless Steel(STS) housing allows excellent anti-corrosiveness and durability
- Mounting bracket allows convenient installation in case of XXX-FT type
- Can select between standard and built-in buzzer type depending on installation environment

S150R / S150R-FT Bulb Revolving Warning Light

Model number	Voltage	Current	Bulb			Certificates	Weight	Color
			Spec	Standard	Parts no			
S150R S150R-FT	DC12V	1.5A	12V15W	G23 15S	17	CE	0.85kg	● R-Red ● A-Amber ● G-Green ● B-Blue
	DC24V	850mA	24V15W	G23 15S	18		0.85kg	
	AC110V	200mA	12V15W	G23 15S	17		1.24kg	
	AC220V	100mA	12V15W	G23 15S	17		1.24kg	

· Suitable for Long distance signal transmission by adopting high capacity bulb and large sized reflector
 ※ CE compliant: DC12V, DC24V

S150RLR / S150RLR-FT LED Revolving Warning Lights

Model number	Voltage	Current	Certificates	Weight	Color
S150RLR S150RLR-FT	DC12V	520mA	-	0.77kg	● R-Red ● A-Amber ● G-Green ● B-Blue
	DC24V	260mA		0.77kg	
	AC110V	80mA		1.16kg	
	AC220V	45mA		1.16kg	

· Excellent omni-directional visibility with LED light collecting system and special multifaceted reflector

Wiring Instructions

- External Power line
UL1015 AWG18(0.75sq) x 2C 400mm
- DC Type
: Black output line is negative(-)
- S150R AC specifications:
110VAC model is connected to black and white wires while 220VAC model is connected to black and red wires.
- S150RLR AC specifications:
AC110V and AC220V can be selected with a built-in 110/220V switch.

Customization

- AC voltage switch built-in type:
AC110V and AC220V can be selected with a built-in 110/220V switch.

Technical Diagram

Units: mm

·S150R / S150RLR

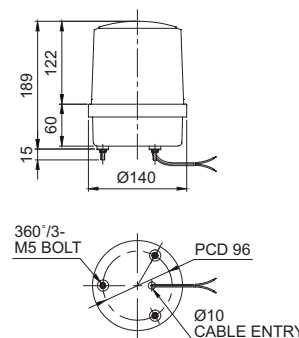

·S150R-FT / S150RLR-FT

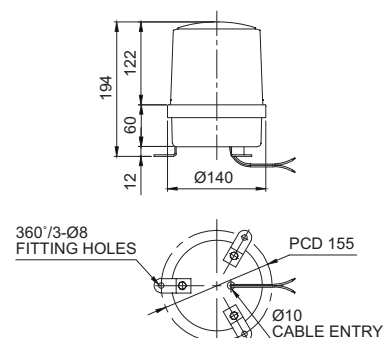

Ordering Specification

S150R	-	BZ	-	220	-	R
[Model number]		[Buzzer option]		[Voltage]		[Color]
S150R		(None)		12-DC12V		● R-Red
S150R-FT		- No buzzer		24-DC24V		● A-Amber
S150RLR		BZ		110-AC110V		● G-Green
S150RLR-FT		- Built-in buzzer		220-AC220V		● B-Blue