

---

**Model: D530/7DD、D530/7DDK**

**Model:D530/7DD (EX)**

**Differential Pressure Switches**

**Explosion-proof Differential Pressure  
Switches**

The sensor is bellow-type, the switches can be suitable for corrosive gas or liquid medium. The Set Point is adjustable, and the adjustable range is from 0.2 to 3MPa. The working pressure range is from 0.05 to 6.3Mpa.

**Main Technical Performance**

	<b>General type</b>	<b>Explosion-proof type</b>
Working viscosity	$<1*10^{-3}m^2/s$	$<1*10^{-3}m^2/s$
Switching Elements	Micro switch	Micro switch
Protection class	---	Exde II CT5
Explosion Class	IP65 (in line with DIN40050)	IP54 (in line with DIN40050)
Ambient temperature	-5℃~40℃	-5℃~40℃
Fluid temperature	0~120℃	0~95℃
Mounting position		Vertical down
Vibrations	D541/7T: 40m/s <sup>2</sup> D541/7TK: 20m/s <sup>2</sup>	Max: 20m/s <sup>2</sup>
Repeatability	≤3%	≤3%
Electrical rating	AC220V 6A(Resistance)	DC250V 0.25A(Resistance) 60Wmax AC250V 5A(Resistance) 1250VAmx

**Features**

Suitable for corrosive medium

**Accessories**

Optional accessories available for ordering Cat.No.: 0574770、0574769、0574758、0574772

---

Specifications

● D530/7DD Switching pressure difference not adjustable

Adjustable Range MPa	Switching pressure difference		Working pressure range MPa *)	Max allowable pressure MPa **)	Number of switching cycles (1/min)	Pressure sensor materials		Connection (male threaded)	Total weight Kg	Dimensional drawing No.		Cat. No.	
	Lower range MPa	Upper range MPa				housing	bellow			General type	Explosion-proof type	General type	Explosion-proof type
0.2...0.1	0.025	0.04		2	10	Stainless steel 00Cr17 1Cr18Ni9Ti (316L)	Stainless steel 00Cr17 Ni14M02 (316L)	G1/2"	1.10	01	03	0819111	0859181
0.02...0.16	0.025	0.04	0.05 到	2	10			G1/2"	1.10	01	03	0819211	0859281
0.025...0.25	0.03	0.05	1.6	2	10			G1/2"	1.10	01	03	0819311	0859381
0.03...0.4	0.03	0.06		2	10			G1/2"	1.10	01	03	0819411	0859481
0.05...0.06	0.06	0.1	0.1 到	3	10			G1/2"	1.05	02	04	0819511	0859581
0.05...1	0.07	0.12	2.5	3	10			G1/2"	1.05	02	04	0819611	0859681
0.05...1.6	0.08	0.14		3	10			G1/2"	1.05	02	04	0819711	0859781
0.1...3	0.08	0.2	0.4 到 6.3	7	10			G1/2"	1.05	02	04	0819715	0859785

● D530/7DDK Switching pressure difference not adjustable (small pressure difference, no explosion-proof type)

Adjustable Range MPa	Switching pressure difference		Working pressure range MPa *)	Max allowable pressure MPa **)	Number of switching cycles (1/min)	Pressure sensor materials		Connection (male threaded)	Total weight Kg	Dimensional drawing No.	Cat. No.
	Lower range MPa	Upper range MPa				housing	bellow				
0.2...0.1	0.01	0.02		2	10	Stainless steel 00Cr17Ni9Ti (316L)	Stainless steel 00Cr17Ni14M02 (316L)	G1/2"	1.10	01	0819113
0.02...0.16	0.01	0.02	From	2	10			G1/2"	1.10	01	0819213
0.025...0.25	0.012	0.025	0.05 to	2	10			G1/2"	1.10	01	0819313
0.03...0.4	0.012	0.03	1.6	2	10			G1/2"	1.10	01	0819413
0.05...0.06	0.25	0.05	From	3	10			G1/2"	1.05	02	0819513
0.05...1	0.03	0.06	0.1 to	3	10			G1/2"	1.05	02	0819613
0.05...1.6	0.04	0.06	2.5	3	10			G1/2"	1.05	02	0819713

0.1...3	0.05	0.15	From 0.4 to 6.3	7	10			G1/2"	1.05	02	0819713
---------	------	------	-----------------------	---	----	--	--	-------	------	----	---------

Remark: \*) High-pressure port medium pressure range.    \*\*) Even short pressure peaks must not exceed this value during actual operation(max. value=max. testing pressure).

### □ 接线示意图

- a. 初始状态：接线端1-2 常闭，接线端1-3 常开。控制装置处于断电不工作状态。见图一；
- b. 压力上升到上切换值时：接线端1-2断开，接线端1-3 闭合。控制装置处于通电工作状态。见图二；
- c. 压力下降到下切换值时：接线端1-2 闭合，接线端1-3 断开，返回到初始状态；

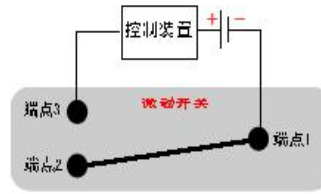

图一

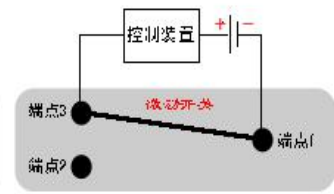

图二

### □ Outline overall and installing dimensions (units:mm)

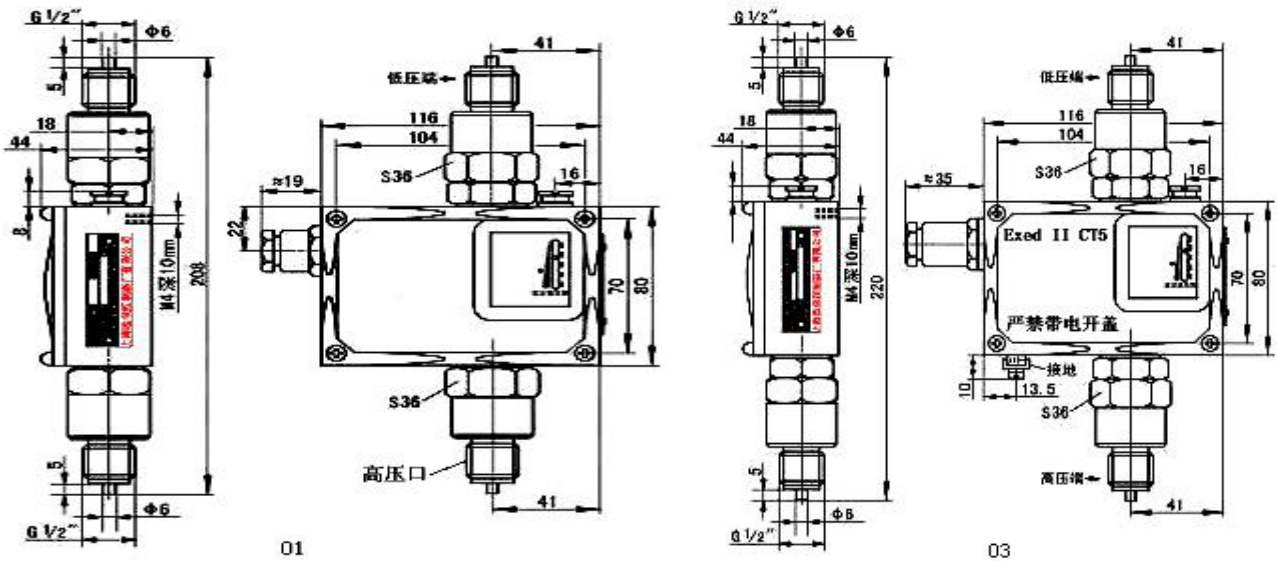

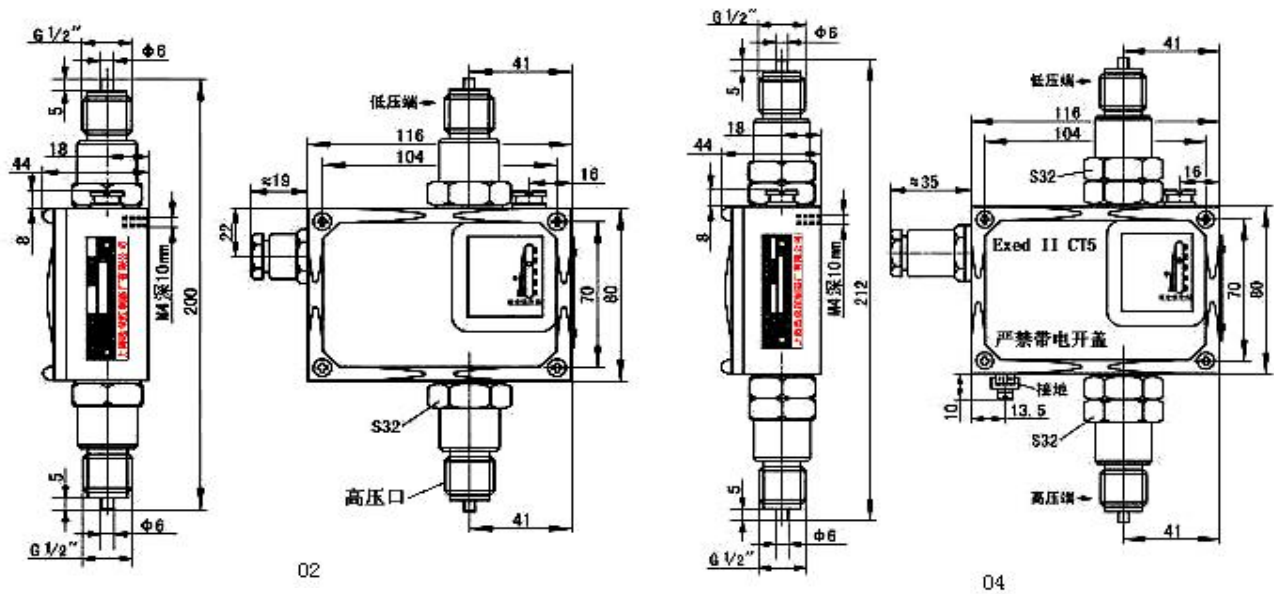

## Switch selection and mounting instructions

Selected controller, it is best to use pre-set value in the controller settings.

The middle part of the adjustment range, (usually 20% ~ 80% of adjustable range).

If the controller is set up outdoor, it should be pretended from dramatic changes in ambient temperature, the sun's radiation, corrosive gases or water infiltration.

For the peak pressure and pulse pressure controlled liquid medium, the controller interface can be installed on a pressure shock damper to eliminate the adverse effects.

Off-current can not exceed the rating.

Install (or demolition) controller to pay attention to: Screwed pipe joints within a depth of no more than 12mm sensor.

## Setting of the switching points

### ● Switching difference not adjustable to adjust the controller setpoint steps

#### Example 1:

Use the differential pressure switch D530/7DD of Cat. No.0819600, and the setting range is from 0.05 to 1MPa. Fall the pressure to 0.5MPa (the next switch value) to a contact single, the steps are as follows:

The product of the high-pressure entrance into the pressure check station rotary screw interface, low pressure air at the entrance to take.

Cable wire access micro-switches on-chip wiring, cables to connect the other end of the multimeter.

The pressure is increased to 0.5MPa, this value can be read out from the standard gauge.

Clockwise rotating adjustment nut to set the value from small to big until the switch contacts shifts in the 0.5MPa.

Check the pressure of the pressure regulating station, so that the pressure is back and forth in 0.5MPa. Check the switching value of contact is 0.5MPa or not when the pressure falls. That is the next switching value to be set. The corresponding value of the upper switch should be 0.5MPa plus switching difference 0.075MPa around, that's 0.425MPa around.

#### Example 2

Use the differential pressure switch D530/7DD of Cat. No.0819500. Fall the pressure to 0.3MPa(the low switch value) to a contact single, the steps are as follows:

The product of the high-pressure entrance into the pressure check station rotary screw interface, low pressure air at the entrance to take.

Cable wire access micro-switches on-chip wiring, cables to connect the other end of the multimeter.

The pressure is increased to 0.3MPa, this value can be read out from the standard gauge.

Clockwise rotating adjustment nut to set the value from small to big until the switch contacts shifts in the 0.3MPa.

Check the pressure of the pressure regulating station, so that the pressure is back and forth in 0.3MPa. Check the switching value of contact is 0.3MPa or not when the pressure falls. That is the next switching value to be set. The corresponding value of the upper switch should be 0.3MPa plus switching difference, that's 0.065MPa around.

设定值调节螺杆 锁定器 密封头

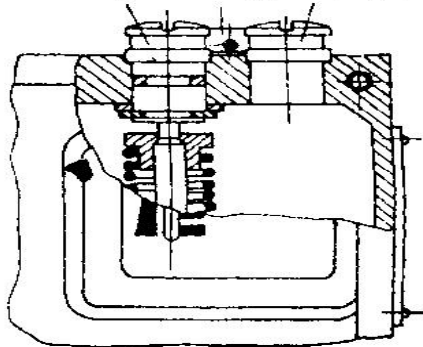

图一

切换差不可调控制器调整示意图