

# SPNA

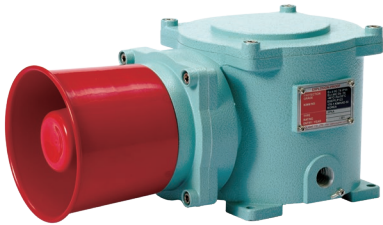

SPNA

## PRODUCT SPECIFICATION

SPNA

**Materials** Housing-Al, Horn housing-STS316L

**Ambient operating temperature**

-20°C ≤ Tamb ≤ +60°C(TS), -40°C ≤ Tamb ≤ +60°C

-40°C ≤ Tamb ≤ +55°C(KCs)

**Sound volume** Max.118dB at 1m

**Explosion protection rating**

IECEX - Ex db IIC T6 Gb, IP66

ATEX - Ex II 2G Ex db IIC T6 Gb, IP66

NEPSI, CCC - Ex db IIC T6 Gb, IP66

KCs - Ex d IIB+H2 IP66 T6(SPNA)

Ex d IIC T6 IP66(SPNAKC)

Ex tD A21 IP65 T85°C(SPNAKC)

TS - Ex db IIC T6 IP66 Gb

**Certificates** IECEX, ATEX, NEPSI, CCC, KCs, CCS, TS

**Housing standard color** MUNSSELL No. 7.5BG 7/2

**Cable entry** 1/2" NPT

- Explosion proof Alarm Horn Sounder
- Various sound tones can be selected ; warning sound, alarm, melody
- Aluminum housing provides excellent durability
- Equipped terminal box for power line wiring in housing

※ Usable voltage AC120V: AC110V-120V, AC230V: AC220V-230V

### SPNA Max.118dB Explosion Proof Electronic Sounder

Model number	Voltage	Current	Sound pattern and volume	Certificates	Weight
SPNA	DC24V	830mA	·WS-5 Warning sounds: Max.118dB ·WP-5 Special warning sounds : Max.118dB		6.09kg
	AC120V	190mA	·WM-5 Melodies: Max.118dB ·WA-5 Alarms: Max.116dB		6.44kg
	AC230V	110mA	·WV-5 Customizable voices: 110-115dB		6.44kg

※ Please refer to [Sound tone and combination for standard product] on this catalogue for detailed sound tone specification

※ Max.built-in volume feature is based on WS, WP-Ch1 / WM-Ch5 / WA-Ch5.

※ In case of customized WV 5 tone type, there may be difference of volume depending on user's audio file type.

### Technical Diagram -SPNA

Units: mm

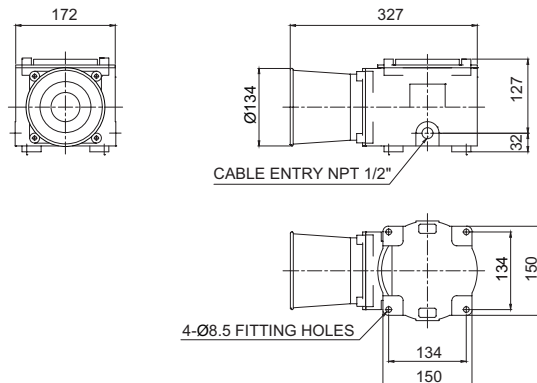

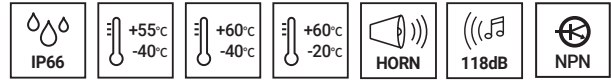

## Sound Selection Instructions and Wiring

- Customization : External contact(LC)  
In case of select sound between external contact and transistors, sound line is threading as customization when product released(LC).

### ·SPNA-DC/AC

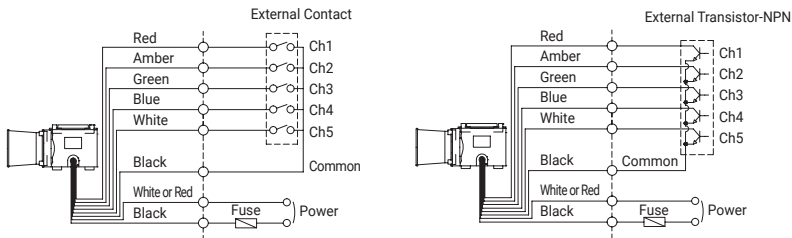

- Standard Type: Select sound using the switch inside of the unit. When you turn on the dip switch for each channel, the designated sound will be played.

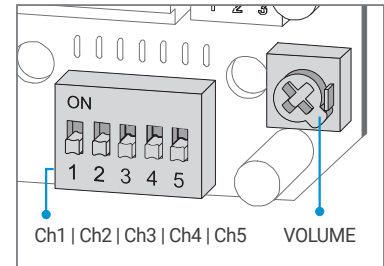

## Customization

- Explosion proof cable gland attached type available (Standard type does not come with explosion proof cable gland)
- 2 ways cable entries
- Customized cable entry (3/4" NPT, M20×1.5, M25×1.5) available
- KCs certified IIC compliant products(SPNAKC)

## Ordering Specification

<b>SPNA</b>	-	<b>WM</b>	-	<b>230</b>	-	<b>LC</b>	-	<b>IECEX</b>
[Model number]		[Sound]		[Voltage]		[Sound selection]		[Certificates]
SPNA		WS-Warning sounds WP-Special warning sounds WM-Melodies WA-Alarms WV-Customizable voices		24-DC24V 120-AC120V 230-AC230V		None-Built-in switch LC-External contact		IECEX ATEX KCs CCC(NEPSI) TS