

SBE Series

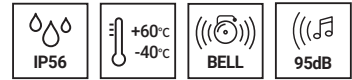

SBE130



SBE150

PRODUCT SPECIFICATION

SBE130 | SBE150

Materials Housing-Al, Bell Housing-Al
Ambient operating temperature $-40^{\circ}\text{C} \leq T_{\text{amb}} \leq +60^{\circ}\text{C}$
Sound volume Max.95dB at 1m
Explosion protection rating
 SBE130: IP56
 SBE150: Ex d IIC T6, IP56
Certificates KIMM
Housing standard color MUNSELL No. 7.5BG 7/2
Cable entry 1/2" NPT

- Explosion proof alarm bell for audible signal in dangerous area
- Adopts special solenoid bell structure, suitable in vessels which encounter serious vibration and impact or outdoor plants application
- Fully enclosed structure with protection rating of IP56

SBE130 / SBE150 Max 95dB Explosion Proof Alarm Bell

Model number	Frequency	Volume	Bell diameter	Voltage	Current	Certificates	Weight
SBE130	400Hz	Max. 95dB	120mm	DC24V	0.055A	-	2.27kg
				AC110V	0.040A		
				AC220V	0.020A		
SBE150	600Hz	Max. 95dB	150mm	DC24V	0.055A	KIMM	2.52kg
				AC110V	0.045A		
				AC220V	0.025A		

Technical Diagram

Units: mm

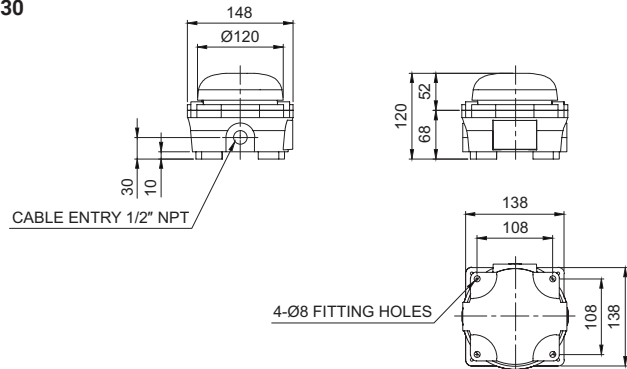

-SBE150

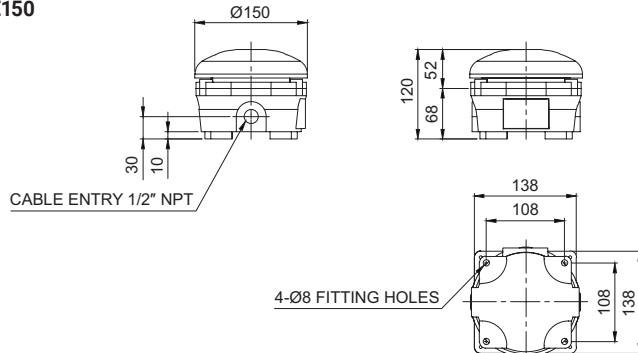

Customization

- Explosion proof cable gland attached type available(Standard type does not come with explosion proof cable gland)
- 2 ways cable entries
- Customized cable entry (3/4" NPT, M20×1.5, M25×1.5) available

Ordering Specification

SBE130	-	220
[Model number]		[Voltage]
SBE130		24-DC24V
SBE150		110-AC110V
		220-AC220V