

SH1/ SH2 series

Heavy-Duty Signal Lights/ Warning Lights
for Vessels and Heavy Industry Applications

Superior durability with fully enclosed structure and corrosion resistance, suitable for vessels and heavy industry applications

- SH1 series-Ø125mm
- SH2 series-Ø150mm



Common Specifications

- Aluminum housing and polycarbonate lens material provides excellent impact resistance under seismic conditions
- Excellent hermetic structure that blocks water and dust
- Can select a variety of light sources (Bulb, LED, and xenon) for your application needs and environmental conditions
- Terminals located inside the terminal box or product
- Cable entry : 1/2"PF
- Materials : Lens-PC, Housing-Al, Protection cage-SUS316L, Reflector for LED type-PC/ Reflector for bulb type-Heat resistant ABS
- Housing standard color : MUNSELL No. 7.5BG 7/2
- Protection rating : IP66

■ A Variety of Selectable Light Source and Function Combinations

You can select from a variety of light sources for your work environment, condition, and purpose. Basic specifications are as follows :

- LED revolving type
- LED steady/flashing type
- xenon lamp strobe type
- Bulb revolving type

User-selected LED strobe type and LED simulated revolving type are available upon request.

1 Lenses

- Utilizes a strong and durable polycarbonate material with excellent shock and vibration resistance
- The lens surface has two types depending on the light source function-Light diffusion type and light transmission type

Light transmission type		LED revolving type Bulb revolving type	SH()LR SH()
Light diffusion type		LED steady/flashing type xenon lamp strobe type	SH()L/LF SH()S

2 Protection cage

- The durable protection cage is made of corrosion resistant stainless steel that prevents damage to the lens from external contact
- Materials : SUS316L



3 Housing

- The special aluminum body housing features superior durability
- The housing is corrosion resistant from a special anodized surface treatment process
- Materials : Al

4 Fully enclosed structure

- The tightly sealed warning light structure is waterproof and dustproof
- Protection rating : IP66

5 Terminal box

- Terminal box is located on the side of housing for easy wiring
- Materials : Al

6 Brackets

- Stainless steel mounting bracket is conveniently attached to the outer surface of the product
- Materials : SUS

SH1/SH2 series Product Categories



Standard model

- Protection cage or terminal box not attached
- Terminals located inside the housing
- Use in environments that has low probability of damage to the lens due to external forces
- SH1/SH2 series is available in this model



Terminal box mounted type

- Equipped with a terminal box for easy wiring
- Terminal box enables easy wiring
- Use in environments that has low probability of damage to the lens due to external forces
- SH1T()/ SH2T() is available in this model



Protection cage mounted type

- Equipped with a Protection cage
- Terminals located inside the housing
- Damage to the lens from external forces can be prevented with protection cage
- SH1()P/SH2()P is available in this model



Terminal box and protection cage mounted type

- Equipped with a protection cage and a terminal box
- Terminal box enables easy wiring
- Damage to the lens from external forces can be prevented with protection cage
- SH1T()P/ SH2T()P is available in this model

SH1S/ SH2S series

Heavy-Duty Xenon Lamp Strobe Signal Lights for Vessels and Heavy Industry Applications



- SH1S-Ø125mm
- SH2S-Ø150mm



SH1S

Common Specifications(SH1S/ SH2S)

- Convenient lamp change with connector type connection structure
- Flashing rate : 60-80 flashes/min
- Standard housing color : MUNSSELL No. 7.5BG 7/2
- Materials : Lens-PC, Housing-Al, Protection cage-SUS316L
- Ambient operation temperature : -30°C to +50°C
- Cable entry : 1/2"PF
- Protection rating : IP66

SH1S Xenon Lamp Strobe Signal Light

- Certificates : CCS(SH1S/ SH1SP), CE

Model number	Voltage	Current	Bulb			Certificates	Color
			Spec	Standard	Parts no		
<ul style="list-style-type: none"> • SH1S Standard type • SH1SP Protection cage type • SH1TS Terminal box type • SH1TSP Protection cage and terminal box type 	DC12V-24V	Max. 1.000A	200V-550V	EUB0641-1A(G) U type	48	 DC only	<ul style="list-style-type: none"> • R-Red • A-Amber • G-Green • B-Blue
AC110V	0.135A						
AC220V	0.105A						

SH2S Xenon Lamp Strobe Signal Light

- Certificates : CE

Model number	Voltage	Current	Bulb			Certificates	Color
			Spec	Standard	Parts no		
<ul style="list-style-type: none"> • SH2S Standard type • SH2SP Protection cage type • SH2TS Terminal box type • SH2TSP Protection cage and terminal box type 	DC12V-24V	Max. 1.000A	200V-550V	EUB0641-1A(G) U type	48	 DC only	<ul style="list-style-type: none"> • R-Red • A-Amber • G-Green • B-Blue
AC110V	0.135A						
AC220V	0.105A						

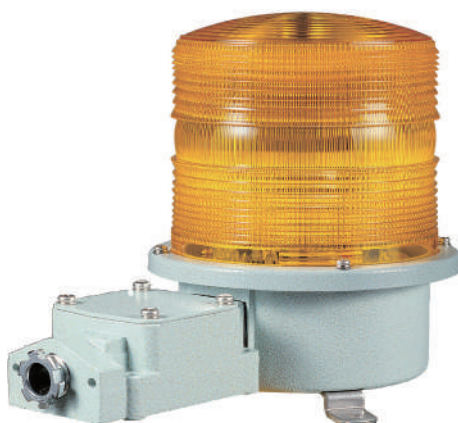

SH2TS

SH1S/SH2S Xenon Strobe Signal Lights Specification Category and Products Weight Chart

Type	SH1S series		SH2S series	
Lens diameter	Ø125mm		Ø150mm	
Standard		SH1S (1.11 kg)		SH2S (1.19 kg)
Built-in protection cage		SH1SP (1.36 kg)		SH2SP (1.48 kg)
Built-in terminal box		SH1TS (1.57 kg)		SH2TS (1.65 kg)
Built-in protection cage & Terminal box		SH1TSP (1.82 kg)		SH2TSP (1.94 kg)

※ Product weight is based on AC type.

SH1S/SH2S models are equipped with flexible connector, and SH1TS/SH2TS models are equipped with 15C nipple at cable entry.



Flexible connector



15C nipple

Ordering Specification

SH1S	-	12	-	R
[Model number]		[Voltage]		[Color]
<ul style="list-style-type: none"> • SH1S • SH1SP • SH1TS • SH1TSP • SH2S • SH2SP • SH2TS • SH2TSP 		<ul style="list-style-type: none"> • 12/24-DC12V-24V • 110-AC110V • 220-AC220V 		<ul style="list-style-type: none"> • R-Red • A-Amber • G-Green • B-Blue

SH1/ SH2 series

Heavy-Duty Signal Lights/ Warning Lights
for Vessels and Heavy Industry Applications



Technical Diagram

(Units : mm)



SH1LRP/ SH1LP/ SH1SP/ SH1P

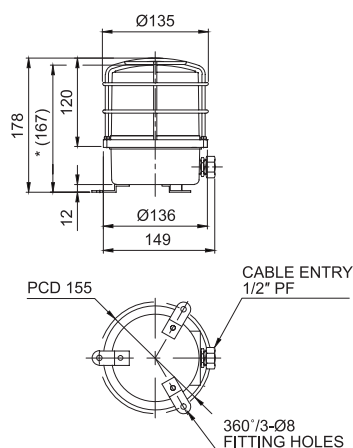

SH1TLRP/ SH1TLP/ SH1TSP/ SH1TP

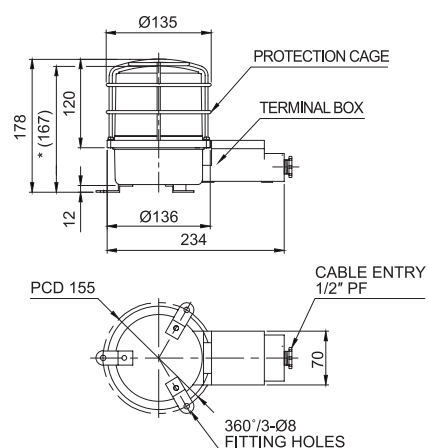

※ *(167) represents SH1LR/ SH1L/ SH1S/ SH1, SH1TLR/ SH1TL/ SH1TS/ SH1T size without protection cage.



SH2LRP/ SH2LP/ SH2SP/ SH2P

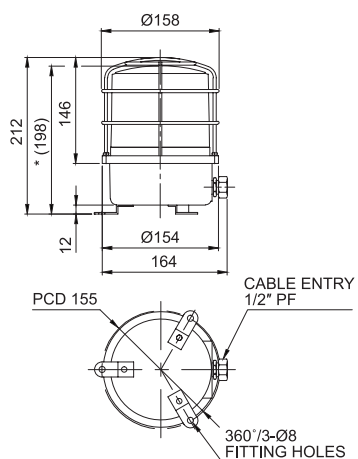

SH2TLRP/ SH2TLP/ SH2TSP/ SH2TP

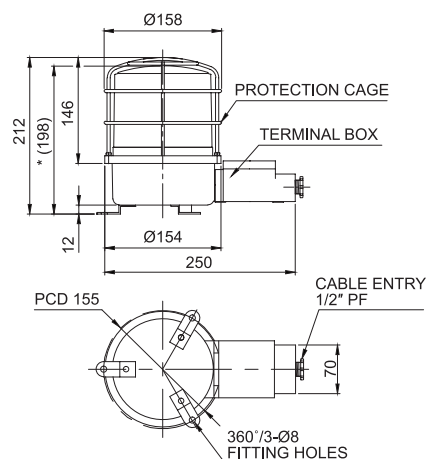

※ *(198) represents SH2LR/ SH2L/ SH2S/ SH2, SH2TLR/ SH2TL/ SH2TS/ SH2T size without protection cage.



Customization

- 3/4"PF cable entry
Standard cable entry is 1/2"PF
3/4"PF is customization
- Built-in cable gland type
Flexible connector is equipped to the standard cable entry
- Brass housing product
SH2 series brass housing provides products with excellent corrosion resistance as customization
※ Color will be MUNSELL No. 7.5BG 7/2 when Released.
- 2T type has 2 cable entries in the terminal box
2 cable entries terminal box is a customized add-on,
please refer to the technical diagram on page 21



Built-in cable gland type



Brass housing product



2 cable entries terminal box model

SH1/ SH2 series

Heavy-Duty Signal Lights/ Warning Lights
for Vessels and Heavy Industry Applications



Technical Diagram for 2T Type Cable Entries

(Units : mm)

SH1LR-2TP/ SH1L-2TP/ SH1S-2TP/ SH1-2TP

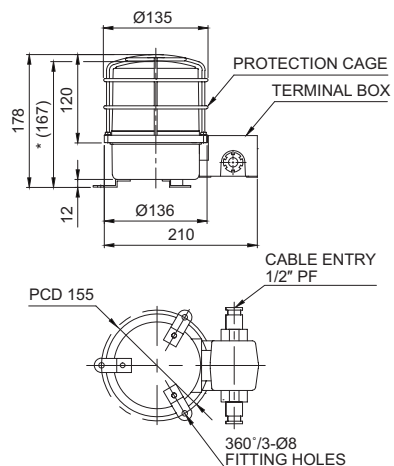

※ *(167) represents SH1LR-2T/ SH1L-2T/ SH1S-2T/ SH1-2T size without protection cage.



SH2LR-2TP/ SH2L-2TP/ SH2S-2TP/ SH2-2TP

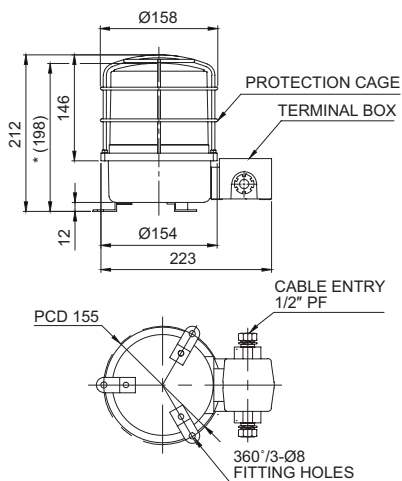

※ *(198) represents SH2LR-2T/ SH2L-2T/ SH2S-2T/ SH2-2T size without protection cage.



Wiring Instructions

- SH1, SH1LR, SH2, SH2LR : Black output line is negative(-)