

7-3

로타리 스위치 (A형) Rotary Switch (A Type)

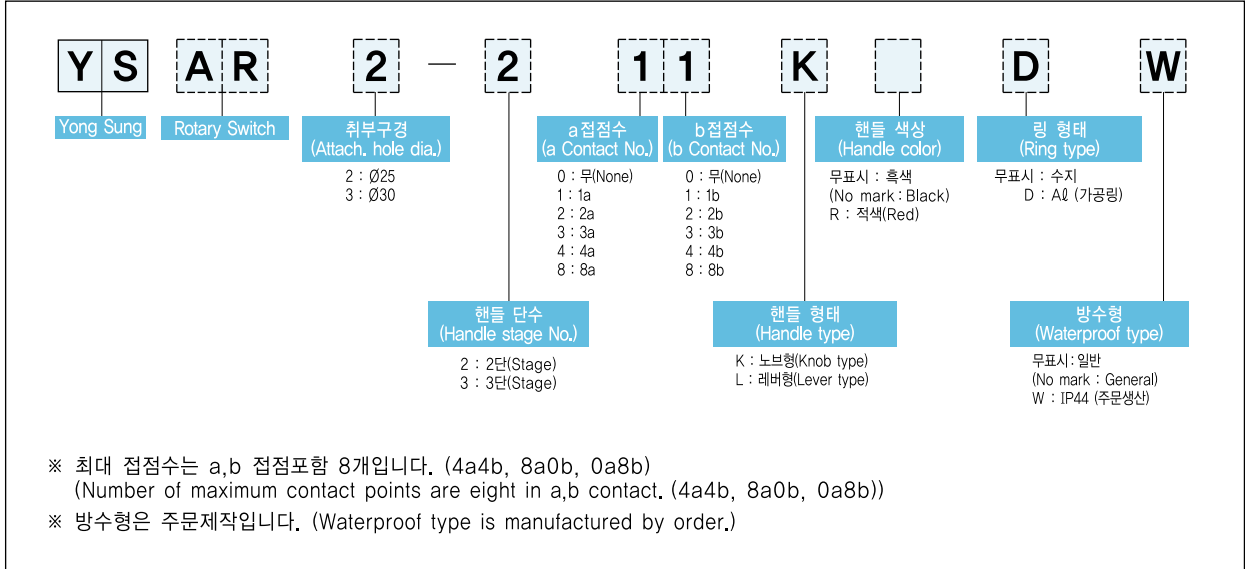

형식 구분도 | Type Classification Diagram



특징 | Features

- 금속부분을 특수합금처리 또는 도금처리하였기 때문에 수명이 매우 깁니다.
- 판넬부착 Ring은 보통 내열성 ABS로 되어 있으나 주문시에는 다이캐스팅 알루미늄으로 대체할 수 있습니다.
- Special alloying or plating treatment on metal parts makes longer life.
- Normal panel attachment ring is heat resistance ABS, but also replaceable by diecasting aluminum upon request.

접점 구성도 (기본 접점) | Contact Form Drawing (Basic Contact)

접점구성번호 (Contact No.)	접점구성 (Contact form)	단자부호 (Terminal code)	2단(2stage)		접점구성번호 (Contact No.)	접점구성 (Contact form)	단자부호 (Terminal code)	3단(3stage)		
			Left	Right				Left	Center	Right
11	1a1b	NO		●	11	1a1b	NO	●		
		NC	●				NC		●	
20	2a	NO		●	20	2a	NO	●		
		NO		●			NO	●		
22	2a2b	NO		●	22	2a2b	NO	●		
		NC	●				NC		●	
		NO		●			NO	●		
		NC	●				NC		●	
40	4a	NO		●	40	4a	NO	●		
		NO		●			NO	●		
		NO		●			NO	●		
		NO		●			NO	●		

핸들 동작 방향도 | Directional Diagram of Handle Action

2단 (2stage)	3단 (3stage)

핸들 종류 | Handle Type

노브형 (Knob Type)	레버형 (Lever Type)

외형 / 치수도 | Shape / Dimension Drawing

(unit : mm)

Knob Type (Ø25)		
<p data-bbox="284 1639 497 1675"> </p>		<p data-bbox="976 1630 1236 1653">(n=CONTACT BLOCK NO.) (최대동작 스트로크)</p>
Knob Type (Ø30)		
<p data-bbox="284 2016 497 2051"> </p>		<p data-bbox="976 2007 1236 2029">(n=CONTACT BLOCK NO.) (최대동작 스트로크)</p>

외형 / 치수도 | Shape / Dimension Drawing |

(unit : mm)

Lever Type (Ø25)

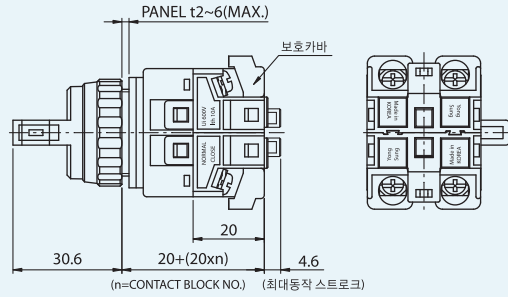
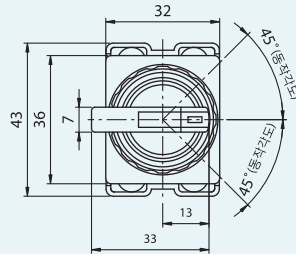

Lever Type (Ø30)

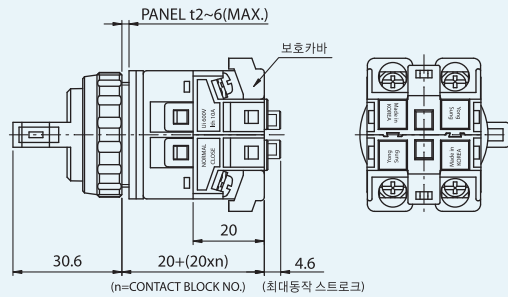
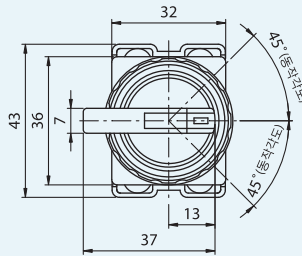

판넬 가공 치수 | Cut-out Dimension |

(unit : mm)

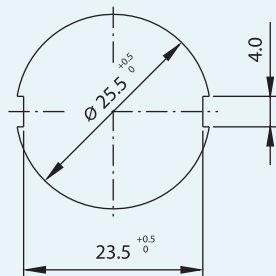

(Ø25)

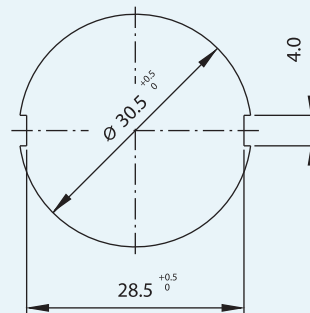

(Ø30)

7-1

제어용 스위치 일반사양
General Specifications Of Control Switch

특징 | Features |

- 스위치부의 개폐가 스프링에 의하여 동작되므로 개폐가 정확하고 저전류에도 사용할 수 있도록 되어 있습니다.
- 측면에서 램프의 점등상태를 확인할 수 있도록 조각형링을 사용하였습니다.
- A,B접점을 일체형으로 하여 전선연결이 보다 쉬워졌습니다. (2A 및 2B는 제작이 불가합니다.)
- 스위치 회로확인 작업시 개폐부를 육안으로 확인할 수 있어 시간이 단축됩니다.
- ※ 참고 : IEC 규격 기준의 접점 구성 설명은 '기술자료 18-5'를 참조하시기 바랍니다.
- By spring switching operation, exact switching and use at low current are possible.
- Carven type ring used for checking lamp lighting state from side.
- Easier wire connection with one switching type of A, B contact. (2A and 2B are not manufactrued.)
- Shortened checking time of switch circuit due to visual checking of switching part.
- ※ Reference : Please refer to 'Technical Data Sheet 18-5' regarding instruction of contact composition based on IEC standard.

성능 개요 | Performance Summary |

형식 (Type)	전구식 (Bulb type)	전전압식 (Overall-voltage type)	LED type
정격전압 (Rated voltage)	AC110V, 220V, 380V, 440V	AC/DC 24V	AC/DC 24V, 48V, 110V, 220V, AC 230V, 240V, 380V, 440V, DC 125V
2차전압 (2nd voltage)	5.5V	-	24V
램프정격 (Lamp rated)	6.3V1W	24V1W	20mA
접점정격 (Contact rated)	AC250V6A		
절연저항 (Insulation resistance)	100MΩ 이상 (Above 100MΩ) (DC 500V. Meg)		
접촉저항 (Contact resistance)	50mΩ 이하 (초기치) (Below 50mΩ, initial value)		
내전압 (Withstand voltage)	AC 2,500V/min (50~60Hz)		
기계적수명 (Mechanical lifetime)	50만회 이상 (Above 500,000 times) (20 times/min)		
전기적수명 (Electrical lifetime)	10만회 이상 (Above 100,000 times) (20 times/min)		
사용주위온도 (Ambient temperature)	-20℃ ~ +55℃		
상대습도 (Relative humidity)	45 ~ 85%		

부품 재질 | Part Materials |

부품 (Part)	재질 (Materials)
하부 (Contact block)	PC 수지 (Polycarbonate resin)
몸체 (Body)	PC 수지 (Polycarbonate resin)
홀더 (Holder)	ABS 내열 수지 (Heat resistance ABS resin)
접점 (Contact)	은합금 (Silver alloy)
단자 (Terminal)	황동 (Brass)
볼트 (Bolt)	탄소강 (Carbon steel)
핸들 (Handle)	ABS 수지 (ABS resin)
버튼 (Button)	아세탈 수지 (Acetal resin)
스프링 (Spring)	스테인레스 (Stainless steel)
캡 (CAP)	AS 수지 (AS resin)
링 (Ring)	ABS 수지, 알루미늄 (ABS resin, Al)

접점 정격 | Contact Rated |

정격절연전압 (Rated insulation voltage)		AC600V, DC250V		
정격통전전류 (Rated conductive current)		10A		
AC	정격사용전압 (Rated voltage)	110V	220V	440V
	저항부하 (Resistive load)	10A	6A	3A
	유도부하 (Inductive load)	5A	2.5A	1.2A
DC	정격사용전압 (Rated voltage)	110V	125V	220V
	저항부하 (Resistive load)	2.2A	1.9A	1.1A
	유도부하 (Inductive load)	1.1A	1.0A	0.6A

단자 극성 | Terminal Polarity |

